

VIBRATION RESPONSE MITIGATION IN MILLING MACHINE USING TUNED MASS DAMPER

Samadhan R Bodke¹, Anil T. Karanjakr², Prof. J. R. Mahajan³

^{1,2} P G Student, ³Assistant Professor, Late G N Sapkal COE Anjaneri Nashik (India)

ABSTRACT

The vibration control of the various machines have been the serious problems in many machining operations. To avoid the chatter vibrations many techniques are preferred. Especially in milling fixtures the vibration control can be achieved using Tuned Mass Dampers. A TMD study with basic DVA study is performed in current work in which initial vibration amplitudes are recorded and for the same vibrational frequency i.e. tuning the secondary system to obtained frequency TMD is designed. After implementation of TMD in gear cutting operation the vibration amplitude in turn life of the fixture and the surface finish obtained on the object is maintained. The same results have been validated using the modal analysis in ANSYS workbench.

Keyword : *TMD, FFT Analyser, Modal Analysis.*

I INTRODUCTION

In the past decades, many control devices have been proposed and studied to reduce the vibrations of the system. One of the designs proposed by Frahm is dynamic vibration absorber. The vibration absorber constitutes an efficient means of introducing damping into structures prone to vibrations i.e. Bridge, high rise building, transmission lines and automobiles.

The original idea is due to Frahm who introduced a spring supported mass, tuned to the natural frequency of the oscillations to be reduced. It was demonstrated by Ormondroyd and Den Hartog that the introduction of damper in parallel with the spring supports of the tuned mass leads to improve behavior, e.g. In the form of amplitude reduction over wide range of frequencies. Many of vibration problems involved in tuned mass absorber involved random loads, e.g. Due to wind or earthquakes. The problems due to vibration in the systems are wear tear, reducing the product quality and tool life. In the design of vibration absorber the mass the stiffness and the applied damping must be selected and the standard procedure is to select suitable stiffness and applied damping, once the mass ratio has been selected [1].

The vibration absorber is a mechanical device used to reduce or eliminate unwanted vibration. It consists of another mass and stiffness attached to the main mass that needs to be protected from vibration. Thus the main mass and the attached absorber mass constitute a two-degree-of-freedom system; hence the vibration absorber will have two

natural frequencies. The vibration absorber is commonly used in machinery that operates at constant speed, because the vibration absorber is tuned to one particular frequency and is effective only over a narrow band of frequencies. Common applications of the vibration absorber include reciprocating tools, such as sanders, saws, and compactors, and large reciprocating internal combustion engines which run at constant speed (for minimum fuel consumption). In these systems, the vibration absorber helps balance the reciprocating forces. Without a vibration absorber, the unbalanced reciprocating forces might make the device impossible to hold or control. Vibration absorbers are also used on high-voltage transmission lines.

The effective damping of mechanical and structural systems oscillations has always been a big challenge for engineers. One of the first attempts to absorb energy of vibrations and in consequence reduce the amplitude of motion is a tuned mass damper (TMD) introduced by Frahm. The device consists of mass on linear spring such that its natural frequency is identical with the natural frequency of damped system. As it is well known, classic TMD is extremely effective in reducing response of the main structure in its resonance but for other frequencies (even close to this resonant frequency) it increases the amplitude of the system's motion. Modification of TMD has been presented in the work of Den Hartog. The author proposes the addition of the viscous damper to Frahm's system design introduced damping TMD become a powerful device that can reduce vibrations of the main body in a wide range of excitation frequencies around principal resonance. Another modification that can lead to broaden the range of TMD effectiveness has been proposed by Roberstson and Arnold. Interchange linear spring of the TMD by the non-linear one (with linear and non-linear parts of stiffness). In recent years much more attention has been paid to the possibility of using purely non-linear spring.

In the present work the designing and the implementation of TMD is studied as well as the TMD is design for the obtained milling vibration frequency. Before that the basic concept of DVA is studied.

II PROBLEM DEFINITION

2.1 Problem Statement

Designing the tuned mass damper for I-section milling machine fixture for gear cutting operation, for reducing the vibration chatter with experimental test using FFT Analyser and FEM analysis.

The above study is carried out by design of TMD and then manufacturing the same, also the FFT analyser is used for vibration parameters investigation with the ANSYS modal analysis.

2.2 Objective

1. To study basics terms related to vibration absorber
2. To implant tuned vibration absorber in vehicle chassis, mass Beneath the bridges platform, mass hanging on transmission Lines with main application as milling machine fixture.
3. To prepare optimum neutralizer.
4. Reduction of vibration frequencies to avoid resonance.

5. Finally improvement in machining operation with reduction of vibration chatter.

2.3 Methodology

Correspondingly the basic study of TMD results in the designing of the TMD based on tunable stiffness for translational motion along the support of the ansys workbench and the FFT analyser fixture as the primary system and the designed TMD as secondary. The obtained primary frequency is tuned to obtain the secondary stiffness and mass. The same is performed in ansys. The results are then investigated for vibration amplitudes and the feasibility for implementation of TMD is suggested.

III LITERATURE REVIEW

The paper titled 'Design and implementation of two-degree-of-freedom tuned mass damper in milling vibration mitigation' by author Yiqing Yang, Wei Dai, Qiang Liu proposed that the two degree of freedom TMD demonstrates better performance than single DOF and two single DOF TMDs with equal mass in vibration mitigating. However its implementation has been limited due to the complexities of design and experimental tuning. It is observed the magnitude of the experimental FRF is 10.8% less reduced than theoretical case. The tuned mass damper (TMD) has been applied to the machining vibration control widely, and it is categorized in to several groups depending on the available degrees of freedom (DOF). Previous works have been mostly focused on the application of single-DOF TMD, but it is revealed that the damping performance could be further promoted by multiple-DOFs TMD. A two-DOFTMD for the milling vibration mitigation is investigated. The TMD possessing translation and rotation motion is designed with tunable stiffness and damping and the design parameters are optimized numerically based on the H1 criterion. The TMD is implemented on a workpiece fixture with single dominant mode, and the experimentally tuned frequency response function (FRF) has 80.8 percent reduction on the amplitude of the flexible mode. Spindle speeds corresponding to the resonance and chatter vibration are selected for the machining tests. The measured vibrations and surface quality validate the improvement of the machining stability by the TMD, and the critical depth of cut is increased at least two folds. The two-DOF TMD demonstrates better performance than single SDOF and two SDOF TMDs with equal mass in the vibration mitigating. However, its implementation has been limited due to the complexities of design and experimental tuning. This paper presents the design and implementation of a two-DOFTMD to damp the dominant mode of the work piece /fixture assembly in milling. The design routine of the TMD is validated by the experimental tuning of the FRF and machining tests. It is evidenced that the amplitude of the flexible mode is reduced 80.8percent after experimental tuning, and the critical depth of cut is increased at least two folds. H1 criterion is selected as the optimization procedure of the TMD, which is specified for the harmonic excitation. The machining tests indicate that it is effective for suppressing both the resonance and chatter vibration of the milling process, although chatter is a special self-excited vibration problem. Additionally, the chatter resistance of the machining system could be further improved by selecting proper tuning criterion specified for the chatter suppression. It is observed the magnitude of the experimentally tuned FRF is 10.8percent less reduced than

the theoretical case.[1]

The paper titled 'On Linear single mass two frequency pendulum tuned mass damper to reduce horizontal vibration' by the author L.D Viet and N.B Nghi proposed a new type of non-linear two DOF pendulum TMD which has better performance at large vibration and is less sensitive than the linear TMD. This paper considers a nonlinear single-mass two-frequency pendulum tuned mass damper (TMD) to reduce horizontal vibration. The proposed TMD contains one mass moving along a bar while the bar can rotate around the fulcrum point attached with the controlled structure. Under horizontal excitation, the single TMD mass has two motions (swing and translation) at the same time and the proposed TMD has two natural frequencies. In comparison with the optimal linear single mass TMD, because of the inherent nonlinearity of the proposed TMD, it has good performance for large vibration. Moreover, the proposed TMD is also less sensitive to the parameter mistuning. The problem is expressed in the non-dimensional equation form. The approximated vibration amplitudes can be obtained by solving a scalar algebraic equation. The numerical simulation is carried out to verify the approximate analysis. The main objective of this paper is to propose a new type of nonlinear two-DOF pendulum TMD, which has better performance at large vibration and is less sensitive than the linear TMD. These advantages are achieved because the proposed TMD at the same time has two motions excited by only one horizontal excitation. The natural frequencies of the swing and translation motions respectively should be tuned to be near the structure frequency and near twice the structure frequency. The problem is presented in the non-dimensional forms. The approximated solutions of the involved system can be obtained by solving only one scalar algebraic equation. The numerical simulation is carried out to justify the conclusions.[8]

IV TUNED VIBRATION ABSORBER

For the effectiveness of absorber at operating frequency corresponding to natural frequency of main system alone

$$\text{we have } \omega_1 = \omega_2 = \frac{k_1}{m_1} = \frac{k_2}{m_2}$$

For this condition we can say that Tuned Absorber. To have a tuned absorber we can have many combinations of k_2 , m_2 as long as their ratio is equal to satisfy the above condition.

We can have a small spring k_2 and small mass m_2 or k_2 large and large mass m_2 . In all these cases main system response will be zero at $\omega = \omega_2$. However, Eq. gives that for equal exciting force the amplitude of is inversely proportional to its spring rate. In order to have small amplitude of absorber mass m_2 , we must have a large k_2 and therefore large m_2 which may not be desirable from practical considerations. So a amplitude and mass ratio μ is generally compromised. The mass ratio is usually kept between 0.05 to 0.2. The denominators of above equation are identical. At a value of ω_1 when these denominators are zero, the two masses have infinite amplitudes of vibration. The expression for the denominators is quadratic in ω_2 therefore there are two values of ω , for which these expression vanish. These two frequencies are resonant frequencies or natural frequencies of the system [2].

V THEORETICAL FORMULATION

When we attach an auxiliary mass m_2 to a machine of mass m_1 through a spring of stiffness k_2 , the resulting two degrees of freedom system will look as shown in Figure

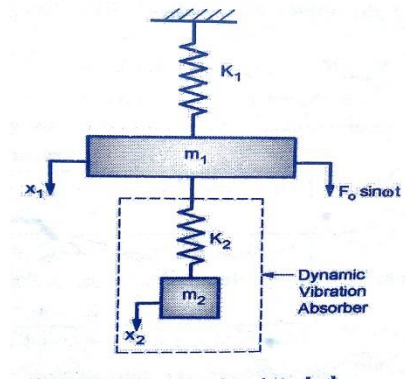

Fig. 1. Two DOF System

The equations of motion of the masses m_1 and m_2 are

$$m_1 \ddot{x}_1 + k_1 x_1 + k_2 (x_1 - x_2) = f_0 \sin \omega t \quad (1)$$

$$m_2 \ddot{x}_2 + k_2 (x_2 - x_1) = 0 \quad (2)$$

By assuming a harmonic solution,

$$x(t) = x \sin \omega t \quad (3)$$

We can obtain the steady state amplitude of masses m_1 & m_2 as we can obtain

$$X_1 = \frac{(k_2 - m_2 \omega^2) f_0}{(k_1 + k_2 - m_1 \omega^2)(k_2 - m_2 \omega^2) - k_2^2} \quad (4)$$

$$X_2 = \frac{k_2 f_0}{(k_1 + k_2 - m_1 \omega^2)(k_2 - m_2 \omega^2) - k_2^2} \quad (5)$$

We are primarily interested in reducing the amplitude of the machine X_1 . In order to make the amplitude of m_1 zero, the numerator of X_1 should be set equal to zero. This gives

$$\omega^2 = \frac{k_2}{m_2}$$

if the machine, before the addition of the dynamic vibration absorber, operates near its resonance,

$$\omega^2 \approx \omega_1^2 = \frac{k_1}{m_1}$$

Thus if the absorber is designed such that

$$\omega^2 = \frac{k_2}{m_2} = \frac{k_1}{m_1}$$

The amplitude of vibration of the machine, while operating at its original resonant frequency, will be zero. By defining

$$\delta_{st} = \frac{f_0}{k_1}$$

$$\omega_1 = \sqrt{\frac{k_1}{m_1}}$$

as the natural frequency of the machine or main system, and

$$\omega_2 = \frac{k_2}{m_2}$$

as the natural frequency of the absorber or auxiliary system, equations. (3) and (4) can be rewritten as

$$\frac{x_1}{\delta_{st}} = \frac{1 - \left(\frac{\omega}{\omega_2}\right)^2}{\left(1 + \frac{k_2}{k_1} - \left(\frac{\omega}{\omega_1}\right)^2\right)\left(1 - \left(\frac{\omega}{\omega_2}\right)^2\right) - \frac{k_2}{k_1}} \quad (6)$$

$$\frac{x_2}{\delta_{st}} = \frac{1}{\left(1 + \frac{k_2}{k_1} - \left(\frac{\omega}{\omega_1}\right)^2\right)\left(1 - \left(\frac{\omega}{\omega_2}\right)^2\right) - \frac{k_2}{k_1}} \quad (7)$$

The variation of the amplitude of vibration of the machine (x_1/δ_{st}) with the machine speed ω/ω_1 . The two peaks correspond to the two natural frequencies of the composite system. As seen before, $x_1(1) = 0$ at $\omega = \omega_1$. At this frequency, equation gives

$$x_2 = \frac{-k_1}{k_2}, \delta_{st} = \frac{-f_0}{k_2}$$

This shows that the force exerted by the auxiliary spring is opposite to the impressed force ($k_2 x_2 = -f_0$) and neutralizes it, thus reducing X_1 to zero. The size of the dynamic vibration absorber can be found from equations (6) and (7)

$$k_2 x_2 = m_2 \omega^2 x_2 = -f_0$$

Thus the values of k_2 and m_2 depend on the allowable value of X_2 . It can be seen from Figure 3 that the dynamic vibration absorber, while eliminating vibration at the known impressed frequency ω , introduces two resonant frequencies Ω_1 and Ω_2 at which the amplitude of the machine is infinite. In practice, the operating frequency must therefore be kept away from the frequencies Ω_1 and Ω_2 .

Initial primary system frequency ω_1 is obtained using FFT analyser i.e. 5 Hz for the same value using above concept the secondary system is tuned i.e. ω_2 .

$$\omega^2 = \frac{k_2}{m_2} = \frac{k_1}{m_1}$$

Assuming the secondary mass as 8 kg

We get K_2 as 8.424 N/mm.

For the above values the structural design of the TMD is done.

VI EXPERIMENTAL SETUP

6.1 Structural Design of TMD

The obtained values of secondary system mass $m_2 = 8\text{kg}$ and stiffness $k_2 = 8.424\text{N/mm}$ the structural design is prepared using catia V5 and analysed using ansys workbench.

The fig 2 represents the structural model of TMD with various dynamic parameters of the structure as well.

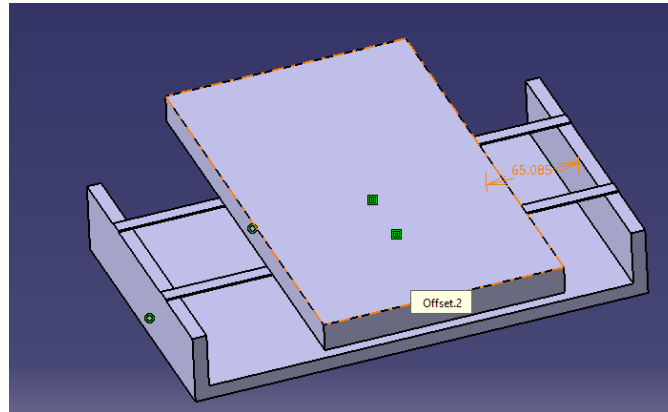

Fig. 2. TMD model

6.2 Experimental Verification

The test was carried on the I shape gear cutting fixture and the

Obtained results were compared with and without implementation of TMD on the structure.

The results are tabulated as

TABLE I

FFT READINGS FOR DISPLACEMENT AS ALARM PARAMETER

Displacement			
With TMD		Without TMD	
Frequency(Hz)	Amplitude (µm)	Frequency(Hz)	Amplitude (µm)
0.0	0.18	5	0.5
2.5	0.35	5	0.39
7.5	0.19	7.5	0.48

Similarly readings for the same gear cutting operation the results were recorded by considering the velocity as alarm parameter which are as follows:

TABLE II
FFT READINGS FOR VELOCITY AS ALARM PARAMETER

Velocity			
With		Without	
Frequency(Hz)	Velocity (mm/s)	Frequency(Hz)	Velocity (mm/s)
7.5	0.05	7.5	81.79
5	0.05	7.5	37.96
5	0.02	7.5	72.07

The setup consists of the milling machine with I fixture and the gear cutting operations was carried out with test accelerometer connected in one direction. Initially vibrational signals were collected through FFT and then the same obtained results were compared. The fig 3 represents the setup for testing.



Fig.3 Experimental Setup

VII MODELLING AND ANALYSIS

As seen in the structural design the model shown in fig 4 model in catia v5 and the same modeled was imported in ansys workbench and modal analysis was performed the mesh model is as shown in fig 4

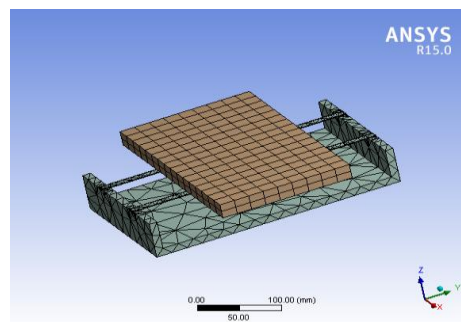

Fig. 4. Meshed TMD model

After modal analysis for the above model resulted frequency was tabulated given as follows in which different mode shapes were investigated.

TABLE III
ANSYS MODE SHAPES RESULTS

Mode	Frequency [Hz]
1.	6.3592
2.	10.694
3.	25.311
4.	92.203
5.	254.65

The obtained results were plotted in following fig 5

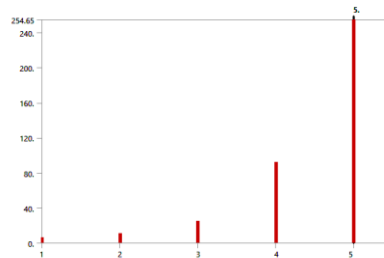

Fig. 5 Plotted Mode Shapes

The fig 5 shows the total deformation for the first mode shape with frequency as 6.3 Hz which is tunable frequency for the primary system and the obtained secondary frequency is for the TMD result. Fig.7 shows the 2D model of TMD with dimensions.

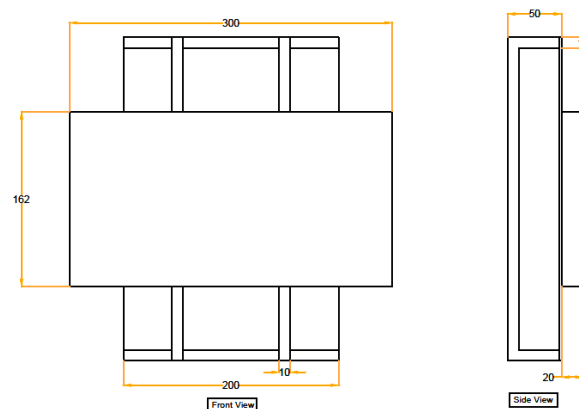

Fig.6 2D model of TMD

The ansys workbench result in fig.7 intimates the numerical result. The stiffness of the spring i.e. two strips is realized and the mass block provides the secondary mass value resulting the formulation of the TMD the primary

vibrations are absorbed approximately negligible amplitudes of the primary system is obtained.

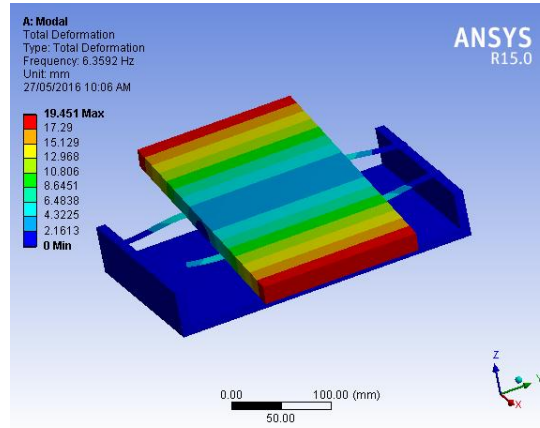

Fig. 7. First mode of vibration for Frequency 6.35 Hz

VIII RESULTS AND DISCUSSION

The following results were obtained from the FFT with were diagnosed in condition monitoring software MCM 2.0 the results are for fixture with and without application of the TMD. The peak values for the various amplitude value by considering the Displacement and Velocity as alarm parameter were considered.

The comparison of result with and without TMD are shown in Figures 8 to 11

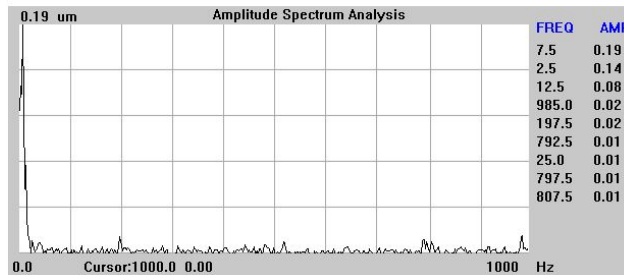

Fig. 8. With TMD Frequency Amplitude for 7.5 Hz and 0.19 μm

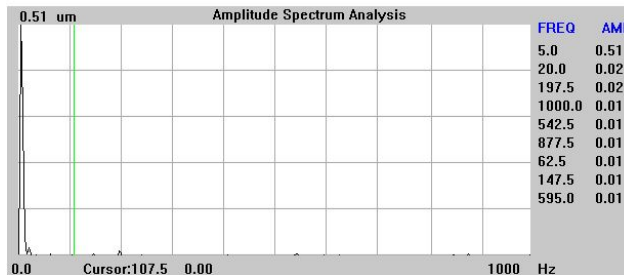

Fig. 9. Without TMD Frequency Amplitude for 5 Hz and 0.51 μm

Similarly by considering the velocity as alarm parameter the FFT readings were taken as

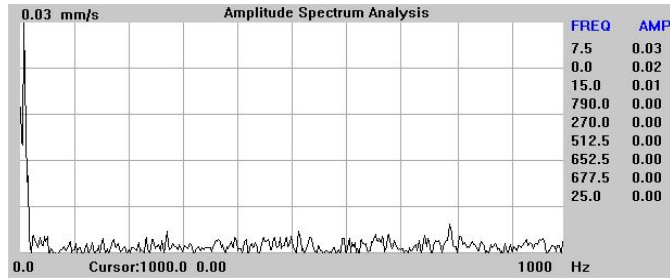

Fig. 10. With TMD Frequency 7.5 Hz and 0.03 mm/s

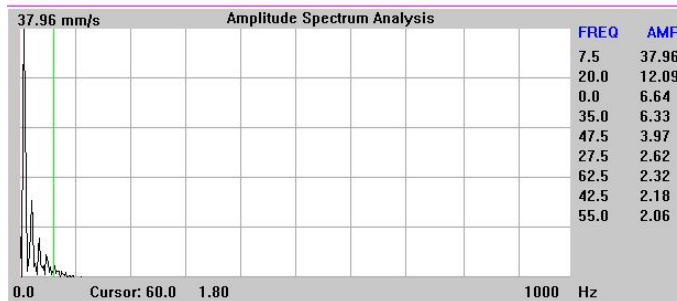

Fig.11. Without TMD Frequency 7.5 Hz and 37.96 mm/s

The obtained results in fig.9 and fig.11 shows that the amplitude of vibrations for the fixture before TMD implementation. Also fig 8 and fig 10 shows the results after implementation. It can be observed that the amplitude of the vibration with TMD is probably reduced from much higher value to lower. This finally reduced the chatter in the milling operations. The same test was carried for different number of times.

TABLE IV

Reduction in FFT Readings for displacement

Displacement			
Without TMD		With TMD	
Frequency(Hz)	Amplitude (µm)	Frequency(Hz)	Amplitude (µm)
5	0.5	0.0	0.18
5	0.39	2.5	0.35
7.5	0.48	7.5	0.19
Average Amplitude	0.45667	Average amplitude	0.24
Reduction in amplitude (%)	47.44		

TABLE V
Reduction in FFT Readings for Velocity

Velocity			
Without TMD		With TMD	
Frequency(Hz)	Velocity (mm/s)	Frequency(Hz)	Velocity (mm/s)
7.5	81.79	7.5	34.86
7.5	37.96	5	15.70
7.5	72.07	5	24.58
Average velocity	63.94	Average velocity	25.05
Reduction in velocity (%)	60.83		

From the above results we can observe that for alarm parameter as displacement approximately 47.44% of the values have been reduced by comparing with and without attaching the tuned mass damper. Same case with alarm parameter as velocity 60.83% has been reduced. Similarly, for FEM results the obtained frequency operating range is 3.5Hz to 8 Hz.

IX CONCLUSION

The results shows that application of TMD dampens the dominant modes shape and gives better performance and surface finish values are improved for the component which is milled. The mitigation of the vibrations for the I-section fixture with Experimental FRF values and the ANSYS validation values gives better idea for designing and implementation of TMD. The same can be applied for different machines, IC Engines for absorption of FRF of the machines.

It is also observed the approximately 47.44 % of the values comparing Experimental and Ansys values finally for the main machine is reduced which is the advantage for machining operation. So by tunable stiffness and mass the TMD can be designed for different operations.

X FUTURE SCOPE

In present work initially study of DVA system is performed, followed with the Tuned mass damper study applicable to milling operation which has dampen the dominant mode of vibration. In future the work can be extended as TMD can be applied for different machining operations on different machines. Moreover TMD in present work is applied uniaxially whereas can be applied to check biaxially to damp structural vibrations in another directions.

ACKNOWLEDGMENT

Thanks to Prof. J.R.Mahajan for his valuable guidance & continuous support during this work.

REFERENCES

- [1] Yiqing Yang, WeiDai, Qiang Liu. “Design and implementation of two-degree-of-freedom tuned mass damper in milling vibration mitigation”, *Journal of Sound and Vibration*, 2015, pp.78-88.
- [2] G.S. Duncan, M.F. Tummmond, T.L. Schmitz, “An investigation of the dynamic absorber effect in high-speed machining”, *International Journal of Machine Tools & Manufacture*, University of Florida, Gainesville,2005, pp.497-502.
- [3] Steen Krenk, Jan Hogsberg, “Tuned mass absorbers on damped structures under random load”, *Probabilistic Engineering Mechanics*, 2008, pp.408-415.
- [4] Y. Yang J.Munoa , Y.Altintas , “Optimization of multiple tuned mass dampers to suppress machine tool chatter” *International Journal of Machine Tools & Manufacture*,2010,pp.834-842.
- [5] Reza MADOLIAT, Sajad HAYATI and Ahmad Ghasemi GHALEBAHMAN, “Modeling and Analysis of Frictional Damper Effect on Chatter Suppression in a Slender End mill Tool”, *Journal of Advanced Mechanical Design, Systems, and Manufacturing*,2011,Vol. 2,No.2,pp.115-128.
- [6] Nicola Carpineto, Walter Lacarbonara, Fabrizio Vestroni, “Hysteretic tuned mass dampers for structural vibration mitigation”, *Journal of Sound and Vibration*, 2013, pp.1-17.
- [7] Steen Krenk, JanHøgsberg, “Tuned mass absorber on a flexible structure”, *Journal of Sound and Vibration*, 2014, pp.1577-1595.
- [8] L.D. Viet, N.B. Nghi, “On a nonlinear single-mass two-frequency pendulum tuned mass damper to reduce horizontal vibration”, *Engineering Structures*, 2014, pp.175-180.
- [9] P.Brzeski, E.Pavlovskaja, T.Kapitaniak, P.Perlikowski, “The application of inerter in tuned mass absorber”, *International Journal of Non-Linear Mechanics*, 2015, pp.20-29.
- [10]Jérémie Monnin, Fredy Kuster, Konrad Wegener, “Optimal control for chatter mitigation in milling—Part1: Modeling and control design”, *Control Engineering Practice*, 2014, pp.156-166.
- [11]Omer F.Tigli , “Optimum vibration absorber (tuned mass damper) design for linear damped systems subjected to random loads ”, *Journal of Sound and Vibration*,2012,pp.3035-3049.
- [12]Min Wang, TaoZan, YiqingYang, RenyuanFei, “Design and implementation of nonlinear TMD for chatter suppression: An application in turning processes”, *International Journal of Machine Tools & Manufacture*, 2010, pp.474-479.